

Aero-Motive Company

W A Woodhead Industries, Inc. Subsidiary

IMPORTANT SAFETY INSTRUCTIONS

Please read this manual carefully and follow its instructions. Improper use or failure to follow these instructions could result in serious injury, death or property damage. Operators should be instructed in the safe and proper use and maintenance of this product. Keep this manual for future reference.

The following safety precautions call attention to potentially dangerous conditions.

! **DANGER:** Immediate hazards which **WILL** result in severe personal injury or death.

! **WARNING:** Hazards or unsafe practices which **COULD** result in severe personal injury or death.

! **CAUTION:** Hazards or unsafe practices which **MAY** result in *minor* personal injury or product or property damage.

INSTALLATION

! **WARNING:** Failure to read, understand, and follow these instructions creates hazards that **COULD** result in personal injury or death.

! **CAUTION:** Instruct operators in the safe, proper use, and maintenance of the reel. Keep this manual for future reference. Hazards or unsafe practices **MAY** result in *minor* personal injury or product or property damage.

MOUNTING

This fixed base reel can be mounted in several different positions as long as following are done.

- Main shaft is horizontal
- Reel is mounted level
- Centerline of the drum is in line with cable run.

If mounted overhead, a secondary support chain needs to be attached to reel to prevent it from accidentally falling.

SECONDARY SUPPORT CHAIN

! **DANGER:** A secondary safety cable or chain is to be attached to all reels mounted overhead to prevent reel from falling. Immediate hazards **WILL** result in severe personal injury or death.

All reels mounted over head are to have a secondary support chain to protect personnel in case of structure or mounting component failure. Attach one end of secondary support chain or cable to secondary support point on reel. Attach other end of secondary support chain or cable to a support component other than that which supports the reel. The chain or cable should be as short as possible allowing reel to drop no more than 6 to 12 inches if the primary connection is released.

CABLE INSTALLATION

! **CAUTION:** Lock out all electrical power and remove all spring tension from the reel before opening any enclosures. Fuse protection should be provided. Fuse size must not be greater than maximum amperage capacity of cable. Hazards or unsafe practices **MAY** result in *minor* personal injury or product or property damage.

NOTE: When reverse winding reel, you will hear a clicking sound as the springs disengage from the spring- motor shaft. This is a safety device and no damage will result from winding. All springs will engage properly when cable is pulled out.

The following steps should be followed when installing cable on reel, remove slip ring cover and slip ring assembly. Remove plate inside junction box, which will allow slip ring assembly and shaft to be pulled out. Insert end of cable through opening in drum, and through watertight connector allowing enough cable for all connections to slip rings. Tighten connector. Strip outer jacket of cable. Be sure to allow enough slack cable to prohibit interference with brushes, then attach to proper brush holder. Replace slip ring and secure shaft. Replace slip ring cover. Wind cable onto reel by reverse winding the spool, i.e., back wind reel until all cable is on spool.

OPERATION

SPRING TENSION ADJUSTMENT

 **CAUTION:** Failure to test for adequate spring revolutions can cause spring damage. Hazards or unsafe practices MAY result in *minor* personal injury or product or property damage.

 **CAUTION:** Prior to terminating cable, follow steps below and make sure that there are no twists or kinks in cable.

Pow-R-Mag lifting capacity is based on three set-up turns of the spring motor shaft. Set-up turns are accomplished by ratchet device attached to end plate.

TENSIONING SPRING

Remove three bolts from cover, and place a bar through holes in the end plate and ratchet assembly. Put bar through holes in spool to prevent spool from turning while tension is being applied. Rotate bar on end plate and ratchet assembly three full turns. Replace three bolts. Repeat for other spring motor.

SERVICE

 **WARNING:** Always disconnect electrical power before dismantling any part of the reel. Fuse size must not be greater than maximum amperage capacity of cable. Remove all spring tension before attempting any service. Hazards or unsafe practices COULD result in *severe* personal injury or death.

SPRING MAINTENANCE

Spring motors have a broken spring indicator. A broken spring can be determined by removing the cover plate on the outside diameter of the spring indicator, toward the top center spring motor. If indicator does not move or can be moved slightly, but returns to its original position, the spring is not broken. If indicator moves freely, and does not return, the spring should be inspected and replaced if necessary.

SPRING REPLACEMENT

 **WARNING:** Before performing any service, always disconnect and lock out all electrical power and always be sure to remove all spring tension before servicing spring motor. Hazards or unsafe practices COULD result in *severe* personal injury or death.

 **WARNING:** Spring is dangerous. Do NOT attempt to remove spring from its container. Hazards or unsafe practices COULD result in *severe* personal injury or death.

If it should become necessary to replace a spring, it can be accomplished either on the reel or at a bench location. Spring tension must be removed. This is done by removing three bolts from the center of the end plate and inserting a bar through holes in the end plate. While holding bar firmly, turn ratchet lever to disengage the ratchet while letting the spring shaft rotate. If the ratchet lever is held the shaft can be rotated until all tension is removed. If ratchet lever is released it will stop the rotation at four different positions while releasing spring tension.

To remove the spring motor for bench repair, remove the four mounting bolts attaching spring motor flange to gearbox. Slide spring motor back until square drive key is disengaged, and take spring motor to work bench.

For spring replacement, remove bolts at center of the end plate (done previously to remove spring tension). Remove tie bolts at the corners of the end plate. Remove the end plate, and remove the outer spring cover. Remove nuts from the ratchet plate, and remove ratchet plate. Remove spring(s) as required by sliding them off the three studs. Reverse procedures above to reassemble spring motor.

NOTE: It is recommended to replace all springs since unbroken springs of same age will likely need replacement very soon as well. Failure to do this will result in much more frequent maintenance.

handling

When disposing of old or broken spring assemblies, coils should be welded or wired together to prevent possible injury to scrap

personnel. Replace broken spring assembly, and reassemble the springs in reverse order. When replacing spring assemblies make sure that the square projection, on the end of the spring hub below, is properly engaged in the opening of adjacent spring cup. Refer to parts drawing for part sequence and location.

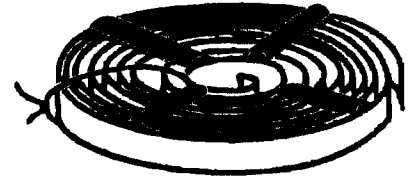

Do **NOT** remove the spring from its container. When removing the rotating hubs, caution must be exercised as stated above.

WARNING: DO NOT ALLOW THE CENTER OF A SPRING TO BE PULLED FROM THE COIL.

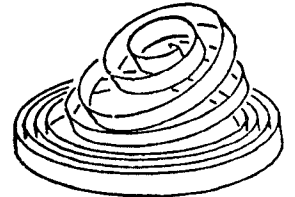

REPLACEMENT OF SLIP RING ASSEMBLY

WARNING: Disconnect and lock out all power to reel before servicing collector ring assembly. Hazards or unsafe practices **COULD** result in *severe* personal injury or death.

CAUTION: Check continuity and replace all covers before turning on electrical power. Hazards or unsafe practices **MAY** result in *minor* personal injury or product or property damage.

Remove slip ring cover, and open junction box. Remove two bolts inside junction box to disengage pin holding shaft. Remove wire connected to slip ring brushes. Pull slip ring assembly and shaft out.

REPLACING SLIP RING ASSEMBLY:

Push slip ring assembly and shaft into bearings in gearbox. Align hole to shaft on junction box side so holding pin may be inserted and bolted. Attach wires to proper brushes. Replace slip ring cover and junction box cover.

MAINTENANCE

LUBRICATION

Spring motors are lubricated for life at the factory. Oil level in the gearbox must be maintained so only the larger gear teeth pass through the oil (approximately 2½" in depth). Do not over-fill. See illustration below.

CAUTION: Over filling the gearbox will result in oil leaking. **ONLY FILL TO THE DEPTH SHOWN.** Hazards or unsafe practices **MAY** result in *minor* personal injury or product or property damage

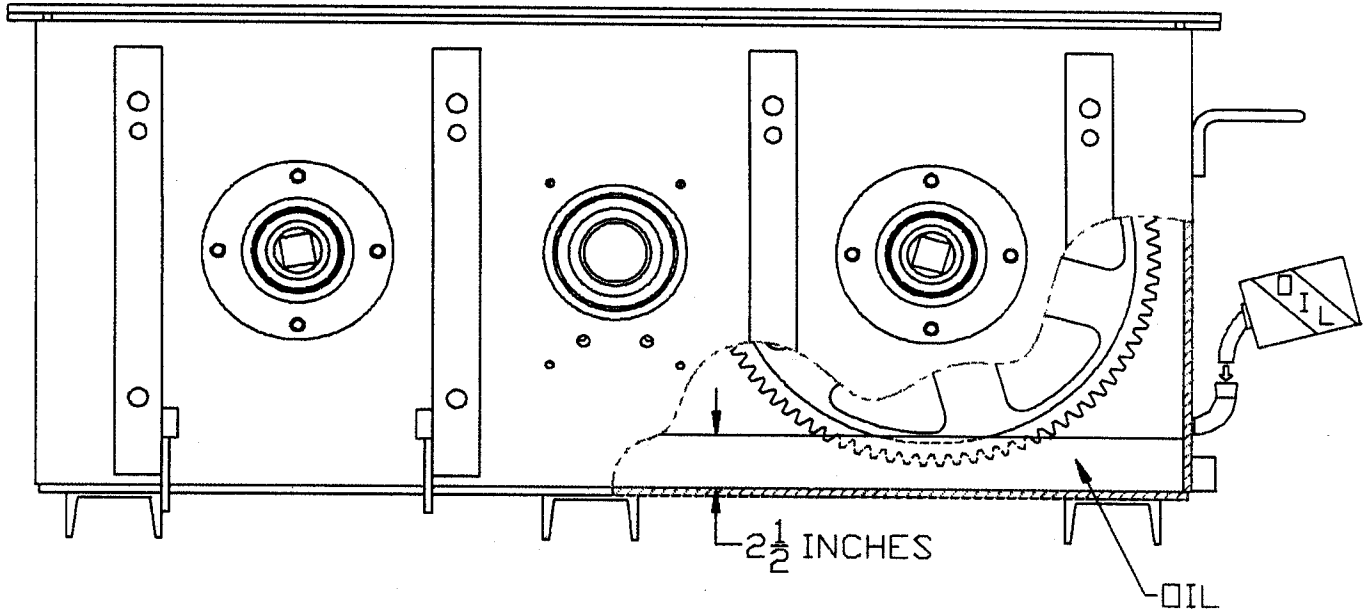

REPLACEMENT PARTS

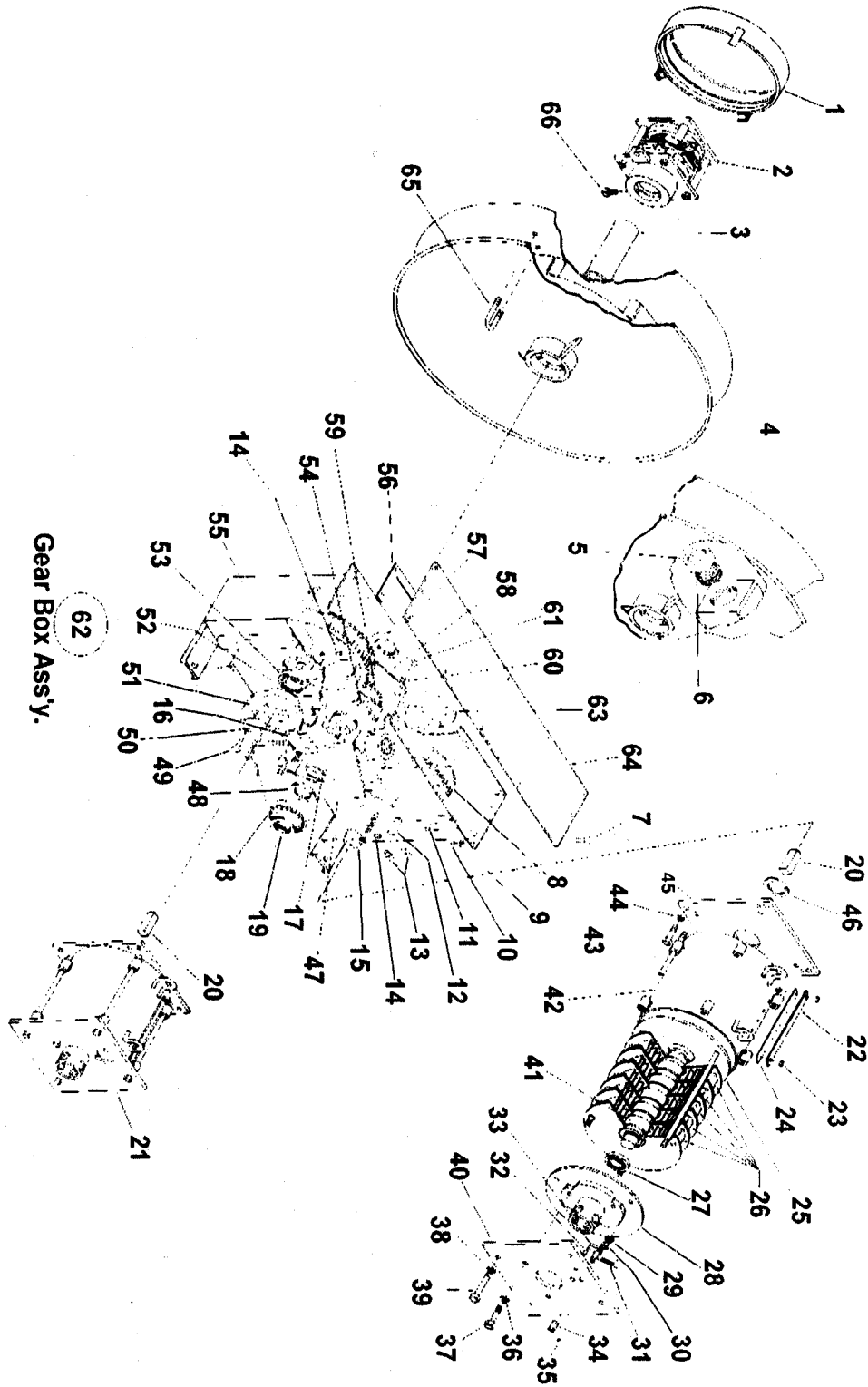

9,0 1,0 -2 3 -6 2 2

SFRIFS	DRUM & FLANGE	# SPRINGS	GEAR BOX	SLIP RING
9	01-11	6- (2) 3-Spring Motors 8- (1) 3-Spring & (1) 5-Spring 0=10- (2) 5-Spring Motors	23	622,623, 624,906

Reference Number *	Part Number	Qty.	Description
1	5641100000	1	Cover; Collector Ring -622
	5644300000	1	Cover; Collector Ring -623, -624
	5656400000	1	Cover; Collector Ring -906
2	SR622	1	Collector Ring -622
	SR623	1	Collector Ring -623
	SR624	1	Collector Ring -624
	6123900007	1	Collector Ring -906
3	5641400000	1	Shaft; Slip Ring
4	5652400000	1	Assembly; Drum & Flange-901
	5652800000	1	Assembly; Drum & Flange-903
	5652700000	1	Assembly; Drum & Flange-904
	5652600000	1	Assembly; Drum & Flange-905
	5653100000	1	Assembly; Drum & Flange-907
	5653500000	1	Assembly; Drum & Flange-909
	5653400000	1	Assembly; Drum & Flange-910
	5653300000	1	Assembly; Drum & Flange-911
5	01151P0014	1	Connector: Cable (.750"-.884" O.D.)
	01151P0016	1	Connector: Cable (.885-1.064" O.D.)
	01151P0017	1	Connector: Cable (1.065"-1.204" O.D.)
	01151P0021	1	Connector: Cable (1.205"-1.374" O.D.)
	01151P0023	1	Connector: Cable (1.375"-1.624" O.D.)
	01151P0026	1	Connector: Cable (1.625"-1.874" O.D.)
6	00748P0004	1	Reducer (.751"-.880" O.D.)
	00748P0003	1	Reducer (.885-1.204" O.D.)
	00748P0002	1	Reducer (1.205"-1.374" O.D.)
7	00030P0112	16	Bolt
8	5641700000	2	Gear
9	00101P0030	16	Washer; Lock (1/4")
10	00151P0020	11	Nut- 1/4-20
11	00230P0154	4	Pin Spring
12	4077300019	3	Key
13	00825P0002	2	Plug; Pipe
14	00053P0502	2	Screw; 3/8-16 x 5/8 Set
15	5625300000	2	Shaft
16	5653800000	1	Shaft Mount Slip Ring
17	00467P0008	2	Sleeve; Bearing
18	00376P0136	1	Bearing
19	00582P0011	1	Ring; Retaining
20	5642400000	2	Key
21	5650000000	AR	Spring Motor Complete (for 3-Spring Motor)
	5650100000	AR	Spring Motor Complete (for 5-Spring Motor)
22	5648800000	1	Plate; Cover (for 3-Spring Motor)
	5648700000	1	Plate; Cover (for 5-Spring Motor)
23	00151P0025	2	Nut; #10-24
24	00682P0003	AR	Gasket

25	5650900000	1	Assembly; End Plate & Stud
26	5649900000	AR	Single Spring
27	00376P0060	1	Bearing
28	5651100000	1	Assembly; End Plate & Ratchet
29	C01010222	4	Washer; Flat 1/2" nom.
30	00160P0045	4	Nut; 3/8-16, Self-Locking
31	5385600000	1	Spring
32	00230P0128	1	Pin
33	5642300000	1	Assembly; Ratchet Dog
34	5648600000	1	Lever; Spring Motor Lock
35	00230P0103	1	Pin
36	00101P0016	3	Washer; 1/2 Spring Lock #6
37	00034P0013	3	Screw; Hex HD Cap
38	00101P0016	4	Washer; 1/2 Spring Lock #6
39	5651300000	4	Bolts (for 3-Spring Motor)
	5651400000	4	Bolts (for 5-Spring Motor)
40	5650400000	1	Plate; Rear Motor
41	5651500000	1	Shaft; Spring Motor (for 3-Spring motor)
	5651600000	1	Shaft; Spring Motor (for 5-Spring Motor)
42	5649700000	1	Housing; Spring Motor (for 3-Spring Motor)
	5649800000	1	Housing; Spring Motor (for 5-Spring Motor)
43	00036P0001	8	Screw; Hex HD Cap
44	00101P0035	8	Washer; Lock
45	5650500000	1	Plate; Motor Mounting
46	00582P0024	1	Ring; External Retaining
47	5654000000	1	Connector Box
48	00582P0026	1	Ring; Retaining
49	00032P0105	20	Screw; 3/8-16 x 7/8
50	00101P0021	20	Washer; Lock
51	5640400000	2	Mount; Inner Bearing
52	5644900000	2	Shaft; Pinion
53	00376P0188	4	Bearing
54	5641300000	1	Gear; Drum
55	5640200000	1	Gear Box
56	00628P0002	1	Gasket
57	00582P0083	1	Ring; Retaining
58	5640500000	1	Mount; Bearing
59	00376P0187	1	Bearing
60	00101P0021	4	Washer; 3/8 Lock
61	00032P0105	4	Screw; 3/8-16 x 7/8
62	5646600000	1	Assembly; Gear Box
	5646700000	1	Assembly; Gear Box
63	5640300000	2	Mount; Outer Bearing
64	5641600000	1	Cover; Gear Box
65	4920100042	1	Clamp; Cable
66	00051P0024	2	Screw; Set
	00051P0022	2	Screw; Set